

Overview of Electric Vehicles Charging Stations in Smart Grids

1st Mohammed Wadi

Electrical & Electronics Engineering Dept.
Istanbul Sabahattin Zaim University
Istanbul, Turkey
mohammed.wadi@izu.edu.tr

2nd Wisam Elmasry

Computer Engineering Dept.
Istanbul Kultur University
Istanbul, Turkey
w.elmasry@iku.edu.tr

3rd Mohammed Jouda

Electrical & Electronics Engineering Dept.
Istanbul Sabahattin Zaim University
Istanbul, Turkey
mohammed.joudai@izu.edu.tr

4th Hossein Shahinzadeh

Department of Electrical Engineering,
Amirkabir University of Technology (Tehran Polytechnic)
Tehran, Iran
h.s.shahinzadeh@ieee.org

5th Gevork B. Gharehpetian

Department of Electrical Engineering,
Amirkabir University of Technology (Tehran Polytechnic)
Tehran, Iran
grptian@aut.ac.ir

Abstract—The extensive incorporation of electric vehicles (EVs) plays a crucial role in mitigating climate change and reducing greenhouse gas emissions within the transportation sector. Establishing a reliable and easily accessible charging network infrastructure for EVs is of utmost importance in mitigating range anxiety, elevating consumer trust, and expediting the widespread adoption of EVs, consequently accelerating the shift towards a sustainable and decarbonized transportation regime. The present review article underscores the growing importance of charging station infrastructure as a pivotal factor in promoting the widespread adoption of EVs and advancing sustainable transportation. This is primarily driven by the exponential rise of EVs globally, which demands the imperative establishment and expansion of charge station infrastructure to cater to the growing demands of the EV industry. This paper extensively examines the most current charging station technologies, encompassing fast charging, wireless charging, and intelligent charging systems. It highlights their advantages, drawbacks, and impacts on EV users, infrastructure developers, and policymakers. This paper aims to elucidate various aspects related to the extensive deployment of charging stations, including infrastructure scalability, grid integration, and interoperability. Moreover, potential solutions, best practices, and ongoing research initiatives about these challenges have been critically analyzed and discussed in this study. Finally, this study provides an in-depth analysis of the prospective prospects of charging station infrastructure, delving into potential advancements, nascent technologies, and research avenues within the domain.

Index Terms—Review, Smart Grids, Electric Vehicles (EVs), Charging Station.

I. INTRODUCTION

The exponential proliferation of electrical vehicles (EVs) has given rise to an urgent requirement for an extensive infrastructure of charging stations to facilitate their extensive implementation. Charge stations assume an indispensable role

in furnishing expedient and reachable charging amenities, thereby facilitating EV users to readily and efficiently replenish the power of their vehicles. Currently, significant advancements have occurred in EV charging station infrastructure. Technological innovations have brought about the emergence of expedited, higher efficiency charging mechanisms, as exemplified by Level 2 and DC fast charging stations [1]. Conversely, DC fast charging stations, frequently situated on interstates and principal thoroughfares, provide high-energy DC charging, facilitating a noteworthy replenishment in minutes [2]. Incorporating intelligent technologies, such as live monitoring, distance management, and transaction systems, has significantly augmented charging stations' dependability and end-user experience. The growth in charge station infrastructure presents promising opportunities, yet various challenges remain to be addressed to enable the efficient implementation of charge stations for EVs. A key obstacle to the widespread adoption of electric vehicles is the limited accessibility of public charging infrastructure. The inadequate allocation of funds, ambiguous regulations, and absence of uniform charging protocols have impeded the growth and proliferation of charging station networks. Moreover, ensuring the optimization of charging infrastructure to address the mounting demand and prevent overload on the grid necessitates deliberate planning and coordinated efforts among stakeholders such as policymakers, utilities, and charging network operators [3]. Despite the numerous challenges and limitations associated with establishing charge stations, the advancement of such facilities offers substantial prospects for an array of interested parties. Governments and regulatory bodies have the potential to play a pivotal role in promoting the deployment of charging stations by implementing financial

incentives, favorable policies, and regulatory frameworks that consolidate interoperability and open access. Implementing sustainable energy sources, namely solar and wind power, within the charge station infrastructure presents an avenue toward a greener and more sustainable charging network. The facilitation of inter-industry collaboration between automakers, utilities, and technology companies presents an opportunity to cultivate innovative approaches, thereby propelling the growth of sophisticated charging alternatives, including but not limited to, wireless and ultra-fast charging technologies [4]. Charge stations for EVs are essential infrastructure components that facilitate the mass adoption of electric vehicles. Advancements in charge station technology have improved charging speeds, efficiency, and user experience. However, challenges surrounding the availability, standardization, and grid integration of charge stations need to be overcome. By tackling these challenges and seizing the opportunities, establishing a comprehensive and resilient charging station network can expedite the shift towards sustainable transportation, mitigate carbon emissions, and improve the overall EV ownership experience. This paper provides a comprehensive review of the charge stations of EVs.

The motivations of this paper can be folded as follows:

- With the rapid growth of EVs worldwide, the development of charge station infrastructure has become increasingly critical. This review paper highlights the significance of this infrastructure in supporting the widespread adoption of EVs and promoting sustainable transportation.
- The field of charge station technology is rapidly evolving, with numerous advancements and innovations. This review paper provides an overview of the latest technologies, such as fast charging, wireless charging, and smart charging systems, highlighting their benefits, limitations, and potential implications for EV users, infrastructure planners, and policymakers.
- Deploying charging stations at scale encounters various challenges, including infrastructure scalability, grid integration, and interoperability. This review paper identifies these challenges and explores potential solutions and current research initiatives dedicated to their effective resolution.
- The field of charge stations for EVs is continually evolving. This review paper offers insights into the future outlook of charge station infrastructure, discussing potential trends, emerging technologies, and research directions.

II. OVERVIEW OF ELECTRIC VEHICLES (EVs)

EVs have emerged as a promising alternative to conventional internal combustion engine (ICE) vehicles, offering numerous benefits in terms of environmental sustainability, energy efficiency, and reduced dependence on fossil fuels. EVs consist of four main components, as given in Figure 1, battery pack which stores and supplies electricity to power the electric motor, electric motor which converts electrical energy into mechanical energy for propulsion, power electronics components

to control the flow of electricity between the battery, motor, and other vehicle systems, and charging system infrastructure to recharge the battery, typically using AC or DC charging methods [5]. There are two main types of EVs, Battery EVs (BEVs) which rely solely on electricity stored in high-capacity batteries for propulsion, and Plug-in Hybrid EVs (PHEVs) that combine an electric motor and a combustion engine, enabling them to run on electricity as well as traditional fuels.

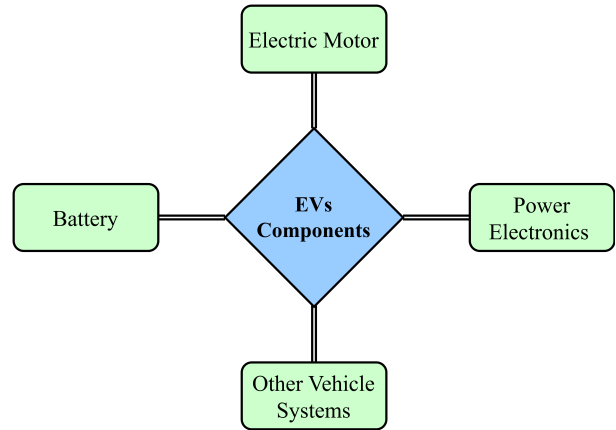

Fig. 1: EVs main components.

EVs present many advantages, including but not limited to environmental benefits, enhanced energy efficiency, and increased energy independence. However, numerous challenges and limitations continue in the field despite notable progress, encompassing inadequacies in charging infrastructure, shortcomings in battery technology, a low market adoption rate, and various other complexities. Table I outlines the advantages and challenges encountered, providing a brief summary of the abovementioned factors.

III. TYPES OF ELECTRIC VEHICLE CHARGING

EV charging can be distinguished by various classifications involving power levels, charging methodologies, and the duration essential for the vehicle's battery to be charged. The present discourse offers an exposition of prevalent forms of EV charging models.

A. Level 1 AC Charging

Charging an electric vehicle through a standard household electrical outlet, known as Level 1 [6], is a primary method within the EV charging ecosystem. This form of charging employs the integrated onboard charger of the vehicle, which facilitates the conversion of AC power to DC power to facilitate the battery charging process. The Level 1 charging method represents the slowest mode of charging and finds applicability when a higher power source is unavailable or when there is a need for overnight charging.

B. Level 2 AC Charging

The operational power of Level 2 [7] charging exceeds that of Level 1 charging, necessitating the utilization of a

TABLE I: Advantages and challenges of EVs.

No	Advantages	Challenges
1.	Environmental Benefits: EVs produce zero tailpipe emissions, reducing air pollution and greenhouse gas emissions.	Charging Infrastructure: The availability and accessibility of charging stations remain key challenges, particularly for long-distance travel.
2.	Energy Efficiency: EVs have higher energy efficiency compared to ICE vehicles, as electric motors convert a greater portion of energy into motion.	Battery Technology: Improvements in battery technology are needed to increase energy storage capacity, reduce costs, and enhance charging speeds.
3.	Cost Savings: EVs have lower operating costs due to lower energy costs and reduced maintenance requirements (fewer moving parts).	Range Anxiety: Limited driving range and the need for recharging infrastructure are concerns for some potential EV buyers.
4.	Energy Independence: EVs reduce dependence on fossil fuels and promote the integration of renewable energy sources.	Market Adoption and Affordability: Wider adoption of EVs requires addressing affordability concerns and ensuring diverse vehicle options.

specialized charging station or wall box. The power source commonly utilized for Level 2 charging is typically more potent, facilitating swifter charging durations compared to Level 1. Level 2 charging is frequently utilized in residential, professional, and communal charging scenarios. Furthermore, the Level 2 charging method is highly favored for Plug-in Hybrid EVs (PHEVs) and Battery EVs (BEVs) with more substantial battery capacities. Figure 2 shows the level 1 and 2 EV charger block diagram.

C. Level 3 DC Charging

The provision of high-power charging capabilities for electric vehicles, commonly referred to as Level 3 charging, is alternatively known as DC fast charging or rapid charging [8]. This charging methodology involves the utilization of high-capacity charging stations that deliver DC to the vehicle's battery, thereby eliminating the necessity for onboard chargers. The implementation of DC fast charging provides a noteworthy reduction in charging durations compared to the Level 1 and Level 2 charging approaches. Public charging stations are often found along highways, enabling extended travel for EVs. Figure 3 shows the level 3 EV charger block diagram.

IV. CHARGING STATION TECHNOLOGIES

EV charging can be categorized into two main types: wired charging and wireless charging. These methods differ in how the power is transferred from the charging infrastructure to the vehicle's battery. Wired charging involves a physical connection between the charging infrastructure and the EV using cables and connectors. The wired charging includes level 1, level 2, and level 3 charging methods. Level 1 and level 2 charging are methods mainly used AC to charge the EVs batteries. Level 3 charging method, also called DC fast charging method includes three different charging approaches, CHAdeMO [9], Combined Charging System (CCS) [10], and Tesla Superchargers (TSC) [11]. "CHAdeMO" is an abbreviation of "Charge de Move," which equivalent to "charge for moving". CHAdeMO is a fast-charging method for EVs that utilizes a specific connector and plug design. It enables DC fast charging, delivering high-power direct current to the vehicle's battery. CHAdeMO charging stations are compatible with Japanese and Korean EV models and are deployed globally, offering power levels ranging from 50 kW to 100 kW, enabling faster charging times compared to lower power alternatives. The CCS is a universally accepted

charging standard for EVs, which integrates both AC and DC charging abilities utilizing a singular connector. The CCS protocol facilitates the utilization of AC charging to ensure compatibility with conventional charging infrastructure while simultaneously enabling the provision of fast DC charging for expedited charging purposes. This technological innovation presents advantageous characteristics in terms of versatility, adaptability towards diverse manufacturers, and a continuously expanding infrastructure of charging facilities, thereby propelling the progression and ease of electric vehicle charging. TSCs represent a distinctive and exclusive DC fast charging architecture devised by Tesla for their EV. The charging rates provided by an entity are highly potent, which results in expedited charging periods and elevated driving distances being made feasible. The Supercharger network offers Tesla owners expedient access to swift charging infrastructure on crucial traveling paths. It is of utmost significance to acknowledge that deploying TSCs is incompatible with other EV models, constraining their exclusive utilization in Tesla automobiles. Inductive charging, commonly known as wireless charging or Wireless Power Transfer (WPT) [12], uses an electromagnetic field to transfer power, eliminating the need for cables and connectors. Wireless charging involves two main components, charging pad (ground unit) and charging receiver (vehicle unit). The charging pad, installed on or embedded in the ground, generates an alternating magnetic field. It is connected to a power source and a control unit that manages the charging process. Whereas, the charging receiver, installed on the EV, consists of a coil that captures the magnetic field generated by the charging pad. It converts the received energy back into electrical energy, which charges the vehicle's battery. Figure 4 shows charging station technologies.

V. OPTIMAL PLACEMENT OF ELECTRIC VEHICLE CHARGING STATIONS

Many research works have been studied the optimal placement of EV charge stations (EVCSs) [13]–[18]. The authors in [16] have proposed an optimal placement strategy for PV stations, supplemented by EV charging stations, to diminish the cost of EV charging. This approach has been formulated using a bilevel programming model. The article also examines PV energy generation, operational costs linked to PV stations, and the distribution of EV charging demands. The present study introduces a bilevel programming optimization model that utilizes photovoltaic panels as power stations to

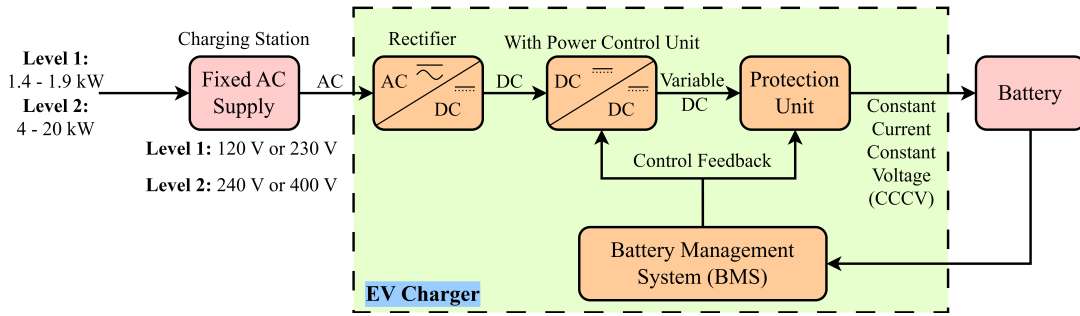

Fig. 2: Level 1 and 2 EV charger block diagram.

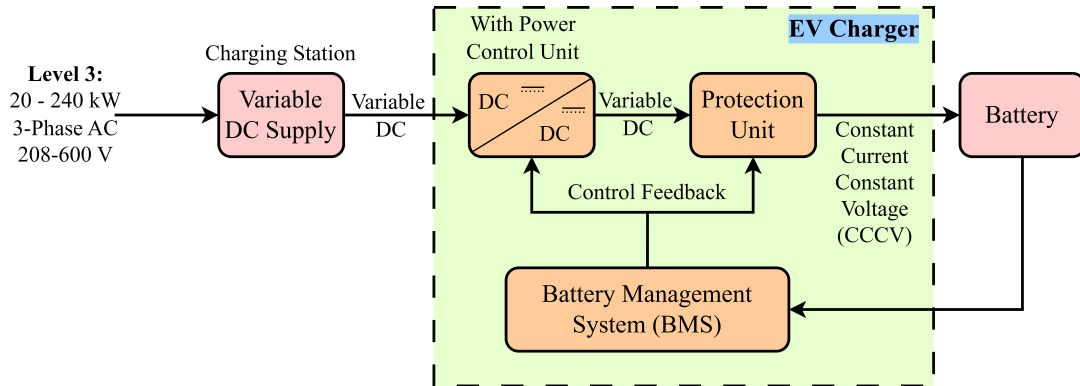

Fig. 3: Level 3 EV charger block diagram.

lower the overall charging cost for EVCSs. The results of the computational models based on empirical data reveal that implementing a PV station can effectively reduce over fifty percent of the expenses incurred during peak hours for charging purposes. The investigation examined the optimal placement of EVCSs on a city scale, focusing on incorporating renewable energy sources, specifically PV panels, as detailed in [17]. The proposed model endeavors to optimize the profits of EVCS proprietors by incorporating regulations of energy management assignment for individual charging stations. It additionally analyzed previous studies on the amalgamation of EVs with sustainable energy sources and the attendant complexities accompanying this process. An optimal placement of EVCSs considering the charging station power, the recharge average time, and traveling distance per day based on the Genetic Algorithm (GA) was proposed in [15]. The primary objective of the proposed approach is to assess the required number of charging stations then identifying the best placement to locate them to satisfy the client's demand.

VI. MULTI-PORT ELECTRIC VEHICLE CHARGING STATIONS

Several studies that consider multi-port charging stations of EVs were appeared in the literature [19]–[23]. Ref. [19] introduced a proposal and validation of a solar PV charging station for electric vehicles that employs multi-port charging and constant current/constant voltage charging. The system considers a station battery that charges when solar power

exceeds the demand for EV charging and discharges when there is a shortage of solar power. The performance of the charging system is validated with simulation and experimental results. Ref. [20] presented a control strategy for optimized charging in multi-port EVCSs. The central aim of the strategy is to prioritize emergency vehicles by providing fast charging services. The present study introduces a novel system employing a bi-directional DC-DC converter with PWM control to enable slow, fast, and reverse charging functionalities. The simulation outcomes indicate that modifying the pulse width of the converter can significantly enhance the charging process in ports, allowing emergency vehicles to prioritize fast charging. The proposed system consists of three distinct ports, one specifically designated for emergency vehicles, while the other two are allocated for other types of EVs. The control methodology facilitates routine charging, decelerated charging for specific vehicles to expedite charging for others and countercharging to expedite the charging process for emergency vehicles.

VII. OFF-GRID CHARGING STATIONS

Many studies concerning off-grid EV charging stations have been appeared in the literature [24]–[27]. An economic analysis of an off-grid photovoltaic solar carport system for charging electric cars in Morocco considering the available parking area and daily energy demand was presented in [24]. The proposed analysis includes capital investment cost, life cycle cost, levelized cost of energy, and payback period. A

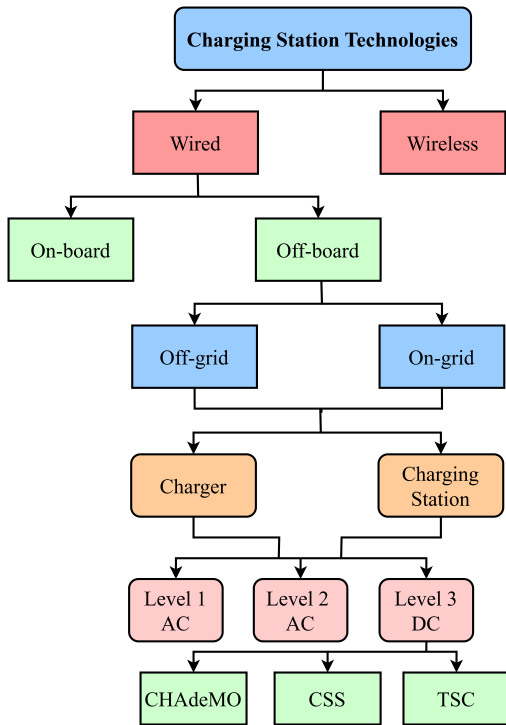

Fig. 4: Charging station technologies.

feasibility study of a partially solar-powered electric tricycle in the ambient conditions of Bangladesh concerning the testing and evaluation of the tricycle in rural and urban areas was discussed in [26]. It investigated the technical details such as energy measurements and battery discharging parameters. Ref. [27] studied the design and simulation of three different DC-DC converters for a solar-powered off-board EV charging station for domestic use. The obtained results showed that all three topologies successfully optimize the battery voltage by tracking the maximum power from the solar PV under different irradiance levels.

VIII. ON-GRID CHARGING STATIONS

Different works considering on-grid EV charging stations have been investigated in the literature [28], [29]. Some of these works concern the integration of renewable sources such as PV [30]–[32] and wind [33]–[35]. Ref. [30] proposed an optimal method for configuring an on-grid charging station for EVs by integrating PV generation and local battery storage. The method under consideration addresses EV mobility, associated uncertainties, the impact of charging stations on the grid, and the stochastic nature of EV charging demand. The findings of the numerical experiments indicate that the deployment of local battery systems plays a crucial role in minimizing the impact on the grid. Moreover, the quantity of chargers deployed is contingent upon the availability of space for local battery systems and PV panels, the volume of electric vehicles arriving at charging stations, and the degree of restrictions on grid impact. An economical and technical study for EVCS with a flywheel and PV was examined

[32]. The cost of flywheel and PV distributed energy sources integration, the cost of optimal sizing, investment, operational, annual maintenance, degradation, and replacement costs were considered. Ref. [33] studied the fast charging for EVs concerning the PV capacity, storage systems, wind turbine, and demand response. The fuzzy-neural network and improved Particle Swarm Optimization (PSO) algorithm were used to forecast the uncertainties with renewable sources [36]–[41]. The study indicated that the utilization of load management by charging stations leads to enhanced profitability and reduces the requirement for significant initial capital investment in an acceptable manner. Wind power as a direct source of energy for EVCSs was discussed in [35]. It presented a technique based on intervals, which corresponds to the duration of time encompassing EV charging, to investigate wind energy conversion. The presented approach was thoroughly evaluated under a variety of constraints and criteria, such as the wind speed averaging time interval, distinct manufacturers of turbines, and commonly used high-resolution wind speed datasets. The results of study demonstrated that the utilization of direct wind-to-EV technology is capable of furnishing a sustained and consistent supply of power that is adequate for the purpose of powering large-scale charging stations [42], [43].

IX. DC-DC CONVERTER TOPOLOGIES

Many valuable research studies have been discussed the used converters in charge stations to reduce the time of charging, the losses, and the maintenance costs [20], [27], [44], [45]. Ref. [44] proposed a practical design for a universal input EV battery charger for a plug-in hybrid vehicle application. The design aims to maintain a high-power factor at the front end while minimizing the ripple current at the output. The proposed design incorporates a PWM boost rectifier coupled with a bidirectional DC-DC converter. A mathematical model has also been developed to portray the charging process in Continuous Conduction Mode (CCM). Ref. [20] presented a comprehensive system design and control approach to achieve optimized charging in a multi-port electric vehicle charging station. The primary goal of this approach was to ensure that emergency vehicles are given priority access to fast charging services. The system under consideration utilized a bi-directional DC-DC converter featuring PWM control to offer incremental charging, rapid charging, and reverse charging competencies [46]. Simulation outcomes indicated that effective management of the pulse width could be leveraged to optimize the charging process at ports, resulting in expedient fast charging for emergency vehicles. A fuzzy logic-based maximum power point tracking (MPPT) system for charging electric vehicle batteries using solar energy was proposed in [45]. The system used a boost converter to extract peak power from the PV panel, a buck converter to step down the voltage to the desired level for battery charging, and a fuzzy logic controller to maintain a constant voltage output for battery charging. Ref. [27] offered a design based on three different DC-DC converter topologies, boost converter, SEPIC topology, and full bridge converter with high frequency

transformer (HFT) for a solar-powered off-board EVCS for domestic use. The results indicate that all three topologies optimize battery voltage by maximizing solar PV power under varying irradiance conditions. The full bridge converter with HFT outperforms the others due to its galvanic isolation and reduced harmonic content.

X. IMPLICATIONS AND RECOMMENDATIONS FOR FUTURE RESEARCH

This review paper extracts many important findings that needed for further researching and developing to meet with the increase integration of EVs and the complex of smart grids, as follows:

- Optimizing renewable resource utilization, implementing fast response storage schemes for fast charging stations, employing intelligent controllers or machine learning techniques to manage grid loading, and incorporating hybrid charging stations with multiple renewable sources or backup diesel generators to enhance system stability and reliability.
- Conduct studies to evaluate the efficiency, cost-effectiveness, and user experience of wireless charging systems in charging stations and identify strategies to overcome potential technical and regulatory barriers.
- Evaluate the potential grid impacts, including voltage fluctuations, power quality issues, and grid congestion, resulting from widespread charging station deployment and propose strategies to mitigate these challenges through grid management techniques.
- Study the effectiveness of intelligent algorithms and demand response strategies in dynamically managing charging station loads, considering factors like user preferences, grid conditions, and electricity pricing to optimize charging efficiency and grid utilization.
- Study the usability, security, and user acceptance of alternative payment methods, such as mobile applications, RFID cards, or subscription-based models, to streamline the charging process and enhance user experience.
- Investigating the impact of different types of EVs on the placement scheme, as different EV models may have different charging requirements and mobility patterns.
- Develop DC fast charging technologies to reduce charging durations while also provisioning designated charging stations for emergency service vehicles to address time-critical situations.
- Formulating more precise forecasting models for EV demand is crucial.
- Assess practical interoperability standards and protocols to improve the compatibility of diverse charging networks, enabling EV users to roam seamlessly and fostering a harmonious and unified charging environment.

XI. CONCLUSION

This review manuscript emphasizes the importance of establishing a durable and easily accessible charging station network to facilitate the widespread assimilation of EVs and

foster sustainable mobility. The aforementioned highlights the imperative nature of EV assimilation in ameliorating the detrimental effects of climate change and diminishing the emission of greenhouse gases. This article comprehensively examines cutting-edge charge station technologies, encompassing rapid charging, wireless charging, and intelligent charging systems. It delves into these technologies' advantages, constraints, and effects on various stakeholders, such as electric vehicle consumers, infrastructure strategists, and policymakers. It additionally elucidates primary limitations in effectively implementing charging stations on a large scale, encompassing infrastructure scalability, grid integration, and interoperability, proposing viable remedies and optimal methodologies. Moreover, this study provides valuable insights into potential avenues for future research endeavors. Specifically, these avenues include but are not limited to the optimization of the utilization of renewable resources, assessment of wireless charging efficiency and user satisfaction, effective management of grid impacts, incorporation of intelligent algorithms for load administration, refinement of payment modalities, consideration of varying electric vehicle models in placement schemes, advancement of rapid charging technologies, fortification of demand forecasting models, and the promotion of standards for interoperability. The implications above underscore the imperative to undertake additional research and development efforts to adequately address the growing convergence of EVs and the intricate functioning of smart grids. Stakeholders can meaningfully progress the development of charging station infrastructure, mitigate the apprehension regarding EV range limitation, augment consumer belief and trust, and expedite the shift towards an environmentally conscious and sustainable transportation ecosystem. In conclusion, the endeavors will aid in accomplishing the overarching objective of mitigating the impacts of climate change and fostering a more sustainable environment for future generations.

REFERENCES

- [1] R. Lamedica, A. Ruvio, P. Falessi, M. Maccioni, E. Sammartino, and M. Palumbo, "Power unit architecture in a high-power charging system for evs," *International Journal of Electrical Power & Energy Systems*, vol. 149, p. 109052, 2023.
- [2] A. M. Mohammed, S. N. H. Alalwan, A. Taşçıkaraoğlu, and J. P. Catalão, "Sliding mode-based control of an electric vehicle fast charging station in a dc microgrid," *Sustainable Energy, Grids and Networks*, vol. 32, p. 100820, 2022.
- [3] S. M. Ahsan, H. A. Khan *et al.*, "Optimized power dispatch for smart building (s) and electric vehicles with v2x operation," *Energy Reports*, vol. 8, pp. 10 849–10 867, 2022.
- [4] C. Attaianesi, A. Di Pasquale, P. Franzese, D. Iannuzzi, M. Pagano, and M. Ribera, "A model-based evs charging scheduling for a multi-slot ultra-fast charging station," *Electric Power Systems Research*, vol. 216, p. 109009, 2023.
- [5] M. Mehrasa, S. Amirkhan, H. P. Souraki, and M. Ahmadijorji, "A robust control strategy for power management of a dc microgrid based on evs in presence of energy storage battery," *Electric Power Systems Research*, vol. 219, p. 109229, 2023.
- [6] R. Lamedica, A. Ruvio, P. Falessi, M. Maccioni, E. Sammartino, and M. Palumbo, "Power unit architecture in a high-power charging system for evs," *International Journal of Electrical Power & Energy Systems*, vol. 149, p. 109052, 2023.

- [7] F. Spaven, Y. Liu, and M. Baghdadi, "Going further with smaller evs: System-level battery range, emissions and charging infrastructure analysis," *Journal of Cleaner Production*, vol. 369, p. 133349, 2022.
- [8] K. Yang and P. Chen, "Optimization of charging schedule for battery electric vehicles using dc fast charging stations," *IFAC-PapersOnLine*, vol. 54, no. 20, pp. 418–423, 2021.
- [9] M. U. Mutarraf, Y. Guan, L. Xu, C.-L. Su, J. C. Vasquez, and J. M. Guerrero, "Electric cars, ships, and their charging infrastructure—a comprehensive review," *Sustainable Energy Technologies and Assessments*, vol. 52, p. 102177, 2022.
- [10] C. Q. Tran, M. Keyvan-Ekbatani, and D. Ngoduy, "Towards clean transportation systems: Infrastructure planning for evs charging while driving," *Sustainable Cities and Society*, p. 104633, 2023.
- [11] Y. Chen, S. D. Chowdhury, and C. Donada, "Mirroring hypothesis and integrality: Evidence from tesla motors," *Journal of Engineering and Technology Management*, vol. 54, pp. 41–55, 2019.
- [12] M. Sheng, A. V. Sreenivasan, B. Sharp, D. Wilson, and P. Ranjitkar, "Economic analysis of dynamic inductive power transfer roadway charging system under public-private partnership—evidence from new zealand," *Technological forecasting and social change*, vol. 154, p. 119958, 2020.
- [13] F. Ahmad, A. Iqbal, I. Ashraf, M. Marzband *et al.*, "Optimal location of electric vehicle charging station and its impact on distribution network: A review," *Energy Reports*, vol. 8, pp. 2314–2333, 2022.
- [14] M. Z. Zeb, K. Imran, A. Khattak, A. K. Janjua, A. Pal, M. Nadeem, J. Zhang, and S. Khan, "Optimal placement of electric vehicle charging stations in the active distribution network," *IEEE Access*, vol. 8, pp. 68 124–68 134, 2020.
- [15] M. Akbari, M. Brenna, and M. Longo, "Optimal locating of electric vehicle charging stations by application of genetic algorithm," *Sustainability*, vol. 10, no. 4, p. 1076, 2018.
- [16] C. Liu, X. Yu, and G. Wen, "Optimal photovoltaic system expansion based on electric vehicle charging station in smart grid," in *2020 IEEE 29th International Symposium on Industrial Electronics (ISIE)*. IEEE, 2020, pp. 166–171.
- [17] L. Yazdi, R. Ahadi, and B. Rezaee, "Optimal electric vehicle charging station placing with integration of renewable energy," in *2019 15th Iran International Industrial Engineering Conference (IIIEC)*. IEEE, 2019, pp. 47–51.
- [18] X. Fang, Y. Wang, W. Dong, Q. Yang, and S. Sun, "Optimal energy management of multiple electricity-hydrogen integrated charging stations," *Energy*, vol. 262, p. 125624, 2023.
- [19] B. P. Yesheswini, S. J. Iswarya, B. Amani, P. Prakash, and M. Sindhu, "Solar pv charging station for electric vehicles," in *2020 international conference for emerging technology (INCET)*. IEEE, 2020, pp. 1–7.
- [20] A. P. Sidharthan and S. Al Arefi, "Optimization of charging in a multi-port ev charging station for emergency vehicle priority fast charging," in *2021 IEEE International Women in Engineering (WIE) Conference on Electrical and Computer Engineering (WIECON-ECE)*. IEEE, 2021, pp. 192–195.
- [21] A. Shekhar, G. C. R. Mouli, S. Bandyopadhyay, and P. Bauer, "Electric vehicle charging with multi-port converter based integration in dc trolley-bus network," in *2021 IEEE 19th International Power Electronics and Motion Control Conference (PEMC)*. IEEE, 2021, pp. 250–255.
- [22] H. Chen, Z. Hu, H. Luo, J. Qin, R. Rajagopal, and H. Zhang, "Design and planning of a multiple-charger multiple-port charging system for pev charging station," *IEEE Transactions on Smart Grid*, vol. 10, no. 1, pp. 173–183, 2017.
- [23] A. P. Sidharthan and S. Al Arefi, "Optimization of charging in a multi-port ev charging station for emergency vehicle priority fast charging," in *2021 IEEE International Women in Engineering (WIE) Conference on Electrical and Computer Engineering (WIECON-ECE)*. IEEE, 2021, pp. 192–195.
- [24] F.-E. Riakhi and A. Khaldoun, "Pv sizing of a stand alone solar carport system linked to charging stations and its economic analysis (a case study)," in *2021 9th International Renewable and Sustainable Energy Conference (IRSEC)*. IEEE, 2021, pp. 1–8.
- [25] A. Kerem, N. Doğan, and A. S. YILMAZ, "Solar-powered off-grid charging station design for electric vehicles," *International Journal of Automotive Engineering and Technologies*, vol. 11, no. 1, pp. 28–37.
- [26] M. F. Bhuiyan, M. R. Uddin, Z. Tasneem, and K. M. Salim, "Feasibility study of a partially solar powered electrical tricycle in ambient condition of bangladesh," in *2018 4th International Conference on Electrical Engineering and Information & Communication Technology (iCEEiCT)*. IEEE, 2018, pp. 495–499.
- [27] S. Koushik and V. Sandeep, "Design and selection of solar powered off-board domestic charging station for electric vehicles," in *2021 International Conference on Sustainable Energy and Future Electric Transportation (SEFET)*. IEEE, 2021, pp. 1–6.
- [28] Z.-j. Pan and Y. Zhang, "A novel centralized charging station planning strategy considering urban power network structure strength," *Electric Power Systems Research*, vol. 136, pp. 100–109, 2016.
- [29] S. Singh, P. Chauhan, and N. J. Singh, "Feasibility of grid-connected solar-wind hybrid system with electric vehicle charging station," *Journal of Modern Power Systems and Clean Energy*, vol. 9, no. 2, pp. 295–306, 2020.
- [30] B. Zhang, Q. Yan, and M. Kezunovic, "Placement of ev charging stations integrated with pv generation and battery storage," in *2017 Twelfth International Conference on Ecological Vehicles and Renewable Energies (EVER)*. IEEE, 2017, pp. 1–7.
- [31] J. Feng, S. Hou, L. Yu, N. Dimov, P. Zheng, and C. Wang, "Optimization of photovoltaic battery swapping station based on weather/traffic forecasts and speed variable charging," *Applied Energy*, vol. 264, p. 114708, 2020.
- [32] Y. Amry, E. Elbouchikhi, F. Le Gall, M. Ghogho, and S. El Hani, "Optimal sizing and energy management strategy for ev workplace charging station considering pv and flywheel energy storage system," *Journal of Energy Storage*, vol. 62, p. 106937, 2023.
- [33] A. Ghasemi-Marzbali *et al.*, "Electric vehicle fast charging station design by considering probabilistic model of renewable energy source and demand response," *Energy*, vol. 267, p. 126545, 2023.
- [34] H. Mehrjerdi and R. Hemmati, "Stochastic model for electric vehicle charging station integrated with wind energy," *Sustainable Energy Technologies and Assessments*, vol. 37, p. 100577, 2020.
- [35] F. Noman, A. A. Alkahtani, V. Agelidis, K. S. Tiong, G. Alkaws, and J. Ekanayake, "Wind-energy-powered electric vehicle charging stations: Resource availability data analysis," *Applied Sciences*, vol. 10, no. 16, p. 5654, 2020.
- [36] W. Elmasry and M. Wadi, "Detection of faults in electrical power grids using an enhanced anomaly-based method," *Arabian Journal for Science and Engineering*, vol. 47, no. 11, pp. 14 899–14 914, 2022.
- [37] M. Wadi, W. Elmasry, and F. A. Tamyigit, "Important considerations while evaluating wind energy potential," *JOURNAL OF THE FACULTY OF ENGINEERING AND ARCHITECTURE OF GAZI UNIVERSITY*, vol. 38, no. 2, pp. 947–962, 2023.
- [38] M. Wadi, W. Elmasry, A. Shobole, M. R. Tur, R. Bayindir, and H. Shahinzadeh, "Wind energy potential approximation with various metaheuristic optimization techniques deployment," in *2021 7th International Conference on Signal Processing and Intelligent Systems (ICSPIS)*. IEEE, 2021, pp. 1–6.
- [39] M. Wadi and W. Elmasry, "Statistical analysis of wind energy potential using different estimation methods for weibull parameters: a case study," *Electrical Engineering*, vol. 103, no. 6, pp. 2573–2594, 2021.
- [40] W. Elmasry and M. Wadi, "Enhanced anomaly-based fault detection system in electrical power grids," *International Transactions on Electrical Energy Systems*, vol. 2022, 2022.
- [41] W. Elmasry and M. Wadi, "Edla-efds: A novel ensemble deep learning approach for electrical fault detection systems," *Electric Power Systems Research*, vol. 207, p. 107834, 2022.
- [42] W. Mohammed, "Five different distributions and metaheuristics to model wind speed distribution," *Journal of Thermal Engineering*, vol. 7, no. Supp 14, pp. 1898–1920, 2021.
- [43] M. Wadi and W. Elmasry, "Modeling of wind energy potential in marmara region using different statistical distributions and genetic algorithms," in *2021 International Conference on Electric Power Engineering–Palestine (ICEPE-P)*. IEEE, 2021, pp. 1–7.
- [44] S. M. Shariff, M. S. Alam, F. Ahmad, Y. Rafat, M. S. J. Asghar, and S. Khan, "System design and realization of a solar-powered electric vehicle charging station," *IEEE Systems Journal*, vol. 14, no. 2, pp. 2748–2758, 2019.
- [45] S. S. Parveen, S. Gupta, and S. Nema, "Fuzzy based solar mppt for electric vehicle application," in *2021 IEEE 2nd International Conference On Electrical Power and Energy Systems (ICEPES)*. IEEE, 2021, pp. 1–5.
- [46] A. Shobole, M. Baysal, M. Wadi, and M. R. Tur, "An adaptive protection technique for smart distribution network," *Elektronika ir Elektrotehnika*, 2020.